

Elbow 90 Equal
Banded F/F

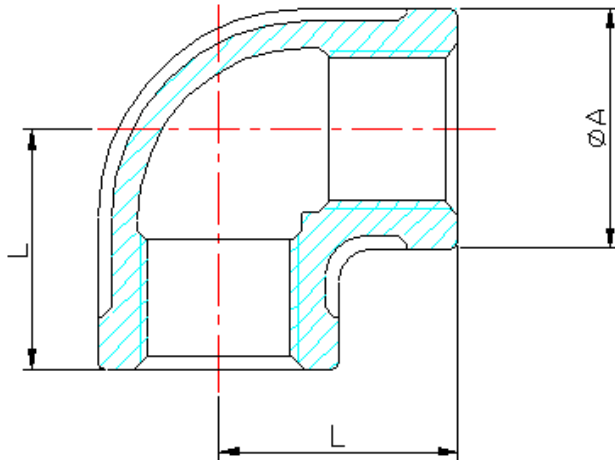

| SIZE | øA | L |
|--------|-------|------|
| 1/8" | 17.0 | 19.0 |
| 1/4" | 21.3 | 21.0 |
| 3/8" | 23.5 | 21.3 |
| 1/2" | 29.0 | 27.0 |
| 3/4" | 36.0 | 33.0 |
| 1" | 43.0 | 38.0 |
| 1 1/4" | 52.0 | 45.0 |
| 1 1/2" | 58.5 | 50.0 |
| 2" | 71.5 | 57.0 |
| 2 1/2" | 87.0 | 69.7 |
| 3" | 99.5 | 77.0 |
| 4" | 126.0 | 98.2 |

Unit: mm

Tee Banded

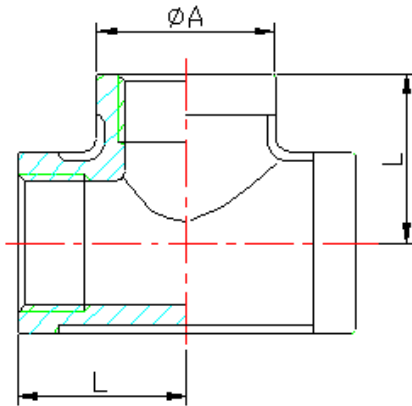

| SIZE | ϕA | L |
|--------|----------|------|
| 1/8" | 17.0 | 19.0 |
| 1/4" | 21.3 | 21.0 |
| 3/8" | 23.5 | 23.6 |
| 1/2" | 30.0 | 28.0 |
| 3/4" | 35.0 | 33.0 |
| 1" | 43.0 | 38.0 |
| 1 1/4" | 52.0 | 45.0 |
| 1 1/2" | 58.5 | 50.0 |
| 2" | 71.5 | 58.0 |
| 2 1/2" | 87.0 | 70.0 |
| 3" | 100.0 | 78.5 |
| 4" | 125.0 | 97.0 |

Unit: mm

Cross Banded

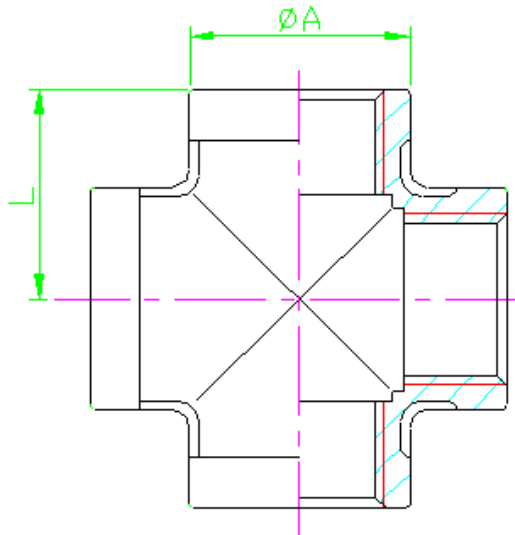

| SIZE | ϕA | L |
|--------|----------|------|
| 1/8" | 15.2 | 17.0 |
| 1/4" | 19.7 | 18.5 |
| 3/8" | 23.3 | 22.9 |
| 1/2" | 28.0 | 26.8 |
| 3/4" | 34.8 | 32.0 |
| 1" | 43.6 | 37.5 |
| 1 1/4" | 53.0 | 45.9 |
| 1 1/2" | 58.0 | 47.6 |
| 2" | 71.0 | 58.0 |
| 2 1/2" | 87.0 | 70.0 |
| 3" | 100.0 | 77.0 |
| 4" | 126.0 | 97.0 |

Unit: mm

Street Elbow 90 M/F

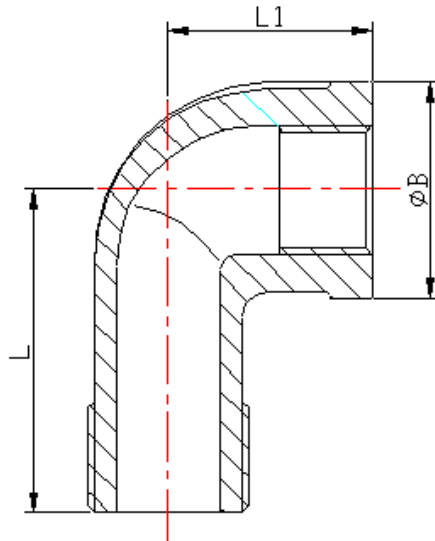

| SIZE | ØB | L | L1 |
|--------|-------|-------|------|
| 1/8" | 17.0 | 25.0 | 19.0 |
| 1/4" | 21.0 | 28.3 | 21.0 |
| 3/8" | 25.0 | 32.0 | 25.0 |
| 1/2" | 29.0 | 42.0 | 28.0 |
| 3/4" | 35.0 | 50.5 | 33.0 |
| 1" | 43.0 | 52.0 | 39.0 |
| 1 1/4" | 52.0 | 60.0 | 45.0 |
| 1 1/2" | 58.8 | 65.0 | 50.0 |
| 2" | 71.7 | 74.0 | 58.0 |
| 2 1/2" | 86.2 | 99.0 | 69.0 |
| 3" | 100.0 | 114.5 | 78.0 |
| 4" | 126.5 | 146.5 | 97.0 |

Unit: mm

Elbow 45 Equal Banded F/F

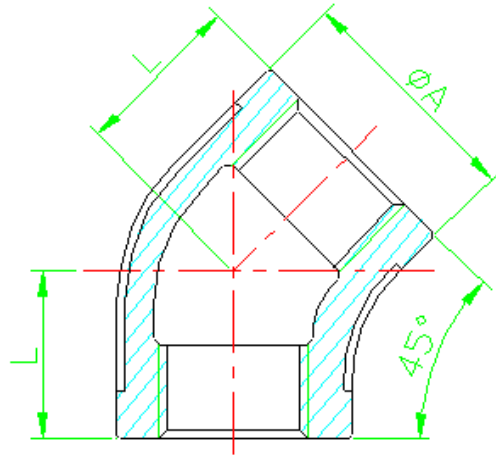

| SIZE | ϕA | L |
|--------|----------|------|
| 1/8" | 18.0 | 18.0 |
| 1/4" | 21.0 | 19.4 |
| 3/8" | 25.0 | 20.0 |
| 1/2" | 29.5 | 22.0 |
| 3/4" | 35.6 | 25.0 |
| 1" | 43.0 | 28.0 |
| 1 1/4" | 52.4 | 33.0 |
| 1 1/2" | 58.0 | 36.0 |
| 2" | 72.0 | 43.0 |
| 2 1/2" | 87.0 | 50.0 |
| 3" | 100.0 | 55.0 |
| 4" | 125.5 | 64.0 |

Unit: mm

Union

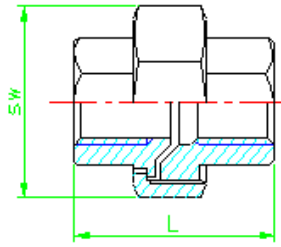

| SIZE | L | Sw |
|--------|-------|-------|
| 1/8" | 29.0 | 25.0 |
| 1/4" | 37.5 | 30.0 |
| 3/8" | 38.0 | 35.0 |
| 1/2" | 42.0 | 42.0 |
| 3/4" | 50.4 | 47.0 |
| 1" | 48.0 | 53.0 |
| 1 1/4" | 59.0 | 71.0 |
| 1 1/2" | 65.0 | 78.0 |
| 2" | 69.0 | 92.0 |
| 2 1/2" | 80.0 | 112.0 |
| 3" | 99.0 | 127.0 |
| 4" | 108.0 | 157.0 |

Unit: mm

Hexagon Plug

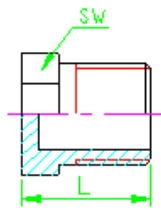

| SIZE | L | Sw |
|--------|------|-------|
| 1/8" | 17.0 | 12.0 |
| 1/4" | 17.5 | 16.0 |
| 3/8" | 18.0 | 20.0 |
| 1/2" | 25.0 | 24.0 |
| 3/4" | 26.0 | 30.0 |
| 1" | 29.0 | 38.0 |
| 1 1/4" | 35.0 | 46.0 |
| 1 1/2" | 38.0 | 52.0 |
| 2" | 39.0 | 65.0 |
| 2 1/2" | 44.0 | 81.0 |
| 3" | 54.0 | 94.0 |
| 4" | 55.0 | 119.0 |

Unit: mm

Square Plug

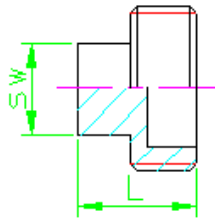

| SIZE | L | SW |
|--------|------|-------|
| 1/8" | 16.5 | 6x6 |
| 1/4" | 20.0 | 9x9 |
| 3/8" | 22.0 | 11x11 |
| 1/2" | 25.0 | 13x13 |
| 3/4" | 27.0 | 16x16 |
| 1" | 32.0 | 20x20 |
| 1 1/4" | 35.0 | 24x24 |
| 1 1/2" | 36.0 | 25x25 |
| 2" | 38.0 | 32x32 |
| 2 1/2" | 48.0 | 42x42 |
| 3" | 52.0 | 46x46 |
| 4" | 62.0 | 58x58 |

Unit: mm

Hexagon Bushing M/F

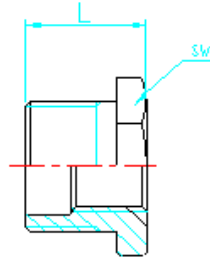

| SIZE | L | Sw |
|-------------|------|------|
| 1/4"x1/8" | 15.2 | 16.0 |
| 3/8"x1/8" | 16.5 | 18.0 |
| 3/8"x1/4" | 16.5 | 18.0 |
| 1/2"x1/8" | 21.0 | 26.0 |
| 1/2"x1/4" | 21.0 | 26.0 |
| 1/2"x3/8" | 21.0 | 26.0 |
| 3/4"x1/8" | 24.0 | 30.0 |
| 3/4"x1/4" | 24.0 | 30.0 |
| 3/4"x3/8" | 24.0 | 30.0 |
| 3/4"x1/2" | 24.0 | 30.0 |
| 1"x1/8" | 27.0 | 35.0 |
| 1"x1/4" | 27.0 | 35.0 |
| 1"x3/8" | 27.0 | 35.0 |
| 1"x1/2" | 27.0 | 35.0 |
| 1"x3/4" | 27.0 | 35.0 |
| 1 1/4"x1/4" | 30.0 | 45.0 |
| 1 1/4"x3/8" | 30.0 | 45.0 |
| 1 1/4"x1/2" | 30.0 | 45.0 |
| 1 1/4"x3/4" | 30.0 | 45.0 |
| 1 1/4"x1" | 30.0 | 45.0 |
| 1 1/2"x3/8" | 38.0 | 52.0 |
| 1 1/2"x1/2" | 38.0 | 52.0 |
| 1 1/2"x3/4" | 38.0 | 52.0 |

| SIZE | øA | øC |
|---------------|------|-------|
| 1 1/2"x1" | 38.0 | 52.0 |
| 1 1/2"x1 1/4" | 38.0 | 52.0 |
| 2"x1/4" | 36.0 | 63.0 |
| 2"x3/8" | 36.0 | 63.0 |
| 2"x1/2" | 36.0 | 63.0 |
| 2"x3/4" | 36.0 | 63.0 |
| 2"x1" | 36.0 | 63.0 |
| 2"x1 1/4" | 36.0 | 63.0 |
| 2"x1 1/2" | 36.0 | 63.0 |
| 2 1/2"x1" | 45.0 | 81.0 |
| 2 1/2"x1 1/4" | 45.0 | 81.0 |
| 2 1/2"x1 1/2" | 45.0 | 81.0 |
| 2 1/2"x2" | 45.0 | 81.0 |
| 3"x1" | 46.5 | 94.5 |
| 3"x1 1/4" | 46.5 | 94.5 |
| 3"x1 1/2" | 47.0 | 95.0 |
| 3"x2" | 47.0 | 95.0 |
| 3"x2 1/2" | 47.0 | 95.0 |
| 4"x1 1/4" | 51.5 | 120.0 |
| 4"x1 1/2" | 51.5 | 120.0 |
| 4"x2" | 52.0 | 120.0 |
| 4"x2 1/2" | 52.0 | 120.0 |
| 4"x3" | 52.0 | 120.0 |

Unit: mm

Round Cap Banded

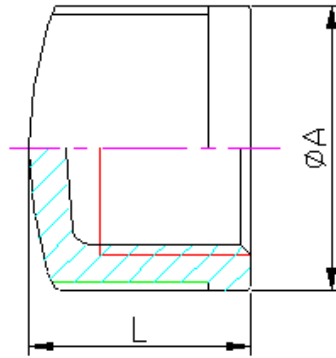

| SIZE | $\varnothing A$ | L |
|--------|-----------------|------|
| 1/8" | 18.0 | 15.0 |
| 1/4" | 21.0 | 17.0 |
| 3/8" | 24.0 | 17.0 |
| 1/2" | 27.3 | 19.0 |
| 3/4" | 35.0 | 24.0 |
| 1" | 42.0 | 29.0 |
| 1 1/4" | 52.0 | 33.0 |
| 1 1/2" | 57.5 | 34.0 |
| 2" | 69.3 | 38.0 |
| 2 1/2" | 92.0 | 41.0 |
| 3" | 106.0 | 47.0 |
| 4" | 134.0 | 53.0 |

Unit: mm

Backnut (Locknut)

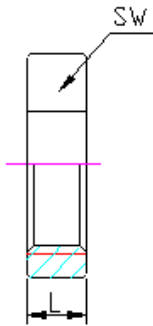

| SIZE | L | Sw |
|--------|------|-------|
| 1/8" | 6.2 | 14.6 |
| 1/4" | 7.0 | 23.0 |
| 3/8" | 8.0 | 26.0 |
| 1/2" | 10.0 | 31.0 |
| 3/4" | 11.0 | 37.0 |
| 1" | 10.0 | 46.0 |
| 1 1/4" | 11.0 | 55.0 |
| 1 1/2" | 12.0 | 63.0 |
| 2" | 13.0 | 76.0 |
| 2 1/2" | 16.0 | 95.0 |
| 3" | 19.0 | 105.0 |
| 4" | 20.0 | 131.0 |

Unit: mm

Coupling

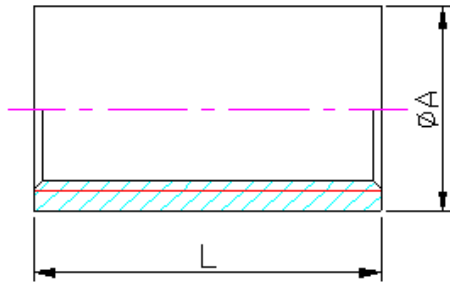

| SIZE | ØA | L |
|--------|-------|------|
| 1/8" | 15.7 | 25.7 |
| 1/4" | 19.7 | 28.0 |
| 3/8" | 22.7 | 30.2 |
| 1/2" | 28.3 | 35.0 |
| 3/4" | 34.9 | 40.4 |
| 1" | 42.0 | 43.7 |
| 1 1/4" | 48.9 | 50.1 |
| 1 1/2" | 57.0 | 56.6 |
| 2" | 71.2 | 65.1 |
| 2 1/2" | 86.3 | 74.0 |
| 3" | 105.7 | 82.0 |
| 4" | 131.3 | 94.5 |

Unit: mm

Half Coupling

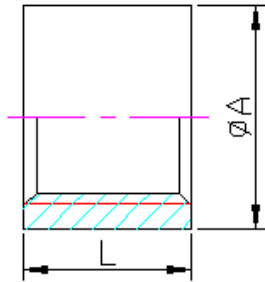

| SIZE | ØA | L |
|--------|-------|------|
| 1/8" | 15.7 | 12.7 |
| 1/4" | 20.0 | 14.6 |
| 3/8" | 23.0 | 15.0 |
| 1/2" | 27.8 | 17.9 |
| 3/4" | 34.2 | 21.4 |
| 1" | 42.1 | 22.3 |
| 1 1/4" | 48.4 | 25.7 |
| 1 1/2" | 56.4 | 28.6 |
| 2" | 70.5 | 33.1 |
| 2 1/2" | 86.0 | 37.8 |
| 3" | 105.0 | 42.0 |
| 4" | 132.0 | 48.5 |

Unit: mm

Coupling Banded Reducing

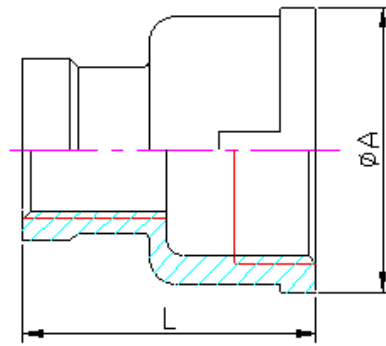

| SIZE | ϕA | L |
|-------------|----------|------|
| 1/4"X1/8" | 21.5 | 26.0 |
| 3/8"X1/8" | 23 | 29.0 |
| 3/8"X1/4" | 26.0 | 29.0 |
| 1/2"X1/8" | 29.0 | 34.5 |
| 1/2"X1/4" | 29.0 | 34.5 |
| 1/2"X3/8" | 29.0 | 34.5 |
| 3/4"X1/8" | 36.0 | 38.5 |
| 3/4"X1/4" | 36.0 | 38.5 |
| 3/4"X3/8" | 36.0 | 38.5 |
| 3/4"X1/2" | 36.5 | 38.5 |
| 1"X1/8" | 43.0 | 42.5 |
| 1"X1/4" | 43.0 | 42.5 |
| 1"X3/8" | 44.0 | 42.5 |
| 1"X1/2" | 44.0 | 42.5 |
| 1"X3/4" | 44.0 | 42.5 |
| 1 1/4"X1/4" | 52.0 | 48.0 |
| 1 1/4"X3/8" | 52.0 | 48.0 |
| 1 1/4"X1/2" | 52.0 | 49.0 |
| 1 1/4"X3/4" | 52.0 | 49.0 |
| 1 1/4"X1" | 52.5 | 52 |
| 1 1/2"X3/8" | 59.0 | 48.0 |
| 1 1/2"X1/2" | 59.0 | 52.0 |
| 1 1/2"X3/4" | 59.0 | 52.0 |

| SIZE | ϕA | L |
|---------------|----------|------|
| 1 1/2"X1" | 59.0 | 53.0 |
| 1 1/2"X1 1/4" | 59.7 | 53.0 |
| 2"X1/2" | 72.0 | 51.0 |
| 2"X3/4" | 72.0 | 51.0 |
| 2"X1" | 72.0 | 56.0 |
| 2"X1 1/4" | 72.0 | 56.0 |
| 2"X1 1/2" | 72.7 | 57.0 |
| 2 1/2"X3/4" | 85.0 | 61.0 |
| 2 1/2"X1" | 87.0 | 61.0 |
| 2 1/2"X1 1/4" | 85.0 | 61.0 |
| 2 1/2"X1 1/2" | 85.0 | 61.0 |
| 2 1/2"X2" | 85.0 | 62.0 |
| 3"X1" | 100.0 | 62.0 |
| 3"X1 1/4" | 100.0 | 62.0 |
| 3"X1 1/2" | 100.0 | 62.0 |
| 3"X2" | 100.0 | 62.0 |
| 3"X2 1/2" | 100.0 | 61.0 |
| 4"X1 1/4" | 128.0 | 65.0 |
| 4"X1 1/2" | 128.0 | 65.0 |
| 4"X2" | 128.0 | 65.0 |
| 4"X2 1/2" | 128.0 | 65.0 |
| 4"X3" | 128.0 | 65.0 |

Unit: mm

Welding Spud

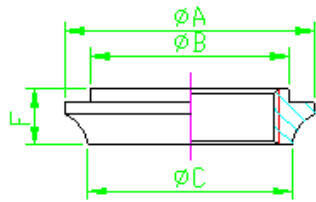

| SIZE | ϕA | ϕB | ϕC | F |
|--------|----------|----------|----------|------|
| 1/8" | 34.7 | 21.0 | 17.8 | 12.0 |
| 1/4" | 37.5 | 24.6 | 20.1 | 13.5 |
| 3/8" | 40.8 | 24.7 | 23.2 | 13.0 |
| 1/2" | 44.5 | 28.8 | 27.9 | 14.9 |
| 3/4" | 48.5 | 33.8 | 33.0 | 16.9 |
| 1" | 56.6 | 42.9 | 42.0 | 19.7 |
| 1 1/4" | 65.6 | 49.1 | 51.9 | 19.0 |
| 1 1/2" | 71.5 | 55.5 | 56.5 | 20.1 |
| 2" | 86.0 | 68.0 | 71.0 | 22.0 |
| 2 1/2" | 98.6 | 79.8 | 81.7 | 24.8 |
| 3" | 114.4 | 93.2 | 97.0 | 24.0 |
| 4" | 143.5 | 119.0 | 124.5 | 26.7 |

Unit: mm