

Find us in

MasterSpec®

Powered by Deltek Specpoint®



CopperPress®
By Merit Brass Co.

Innovative Solutions

Driven to Provide Value to Your System



**MERIT
BRASS**

DIRECTING THE FLOW OF *Quality*

www.meritbrass.com
www.mbwebxpress.com

Streamlining Project Planning & Execution

Save **30-50%** in project planning, cost & execution



Supporting Distribution Growth Strategies Through Vertical Market Relationship Building



Training at Every Stage of the Process with Your Success in Mind



Saves Time, Money & Labor

No Soldering or Burn Permit Needed. Shorter Lay Lengths for Those Tighter Spaces

FEATURES & BENEFITS

EPDM

50-Year Limited Warranty. Available in Sizes 1/2" - 4" Copper Tube Size (CTS). Fully Captured Grab Ring on 2 - 1/2" & above. VIPR® facilitates immediate identification of unpressed connection as well as application

FIRST TO MARKET



Box, Bag and Ring are color-coordinated for ease of identifying the sealing element

Leak Before Press (LBP) System Designed to leak before they are pressed, giving a visual indication of a connection that has not been pressed. 1/2" has a 3-Path LBP, 3/4" - 2" have a 4-Path LBP System. 2.5" - 4" also have LBP.



Water application stamped on the fitting as H₂O in green

NSF 61 on fittings

APPROVED APPLICATIONS

TYPES OF SERVICE	SYSTEM OPERATING CONDITIONS			COPPERPRESS® SEAL	
	NOTES	PRESSURE	TEMPERATURE	EPDM	
FLUIDS/ WATER	Chilled Water	Ethylene Glycol/Propylene Glycol	300 psi	32°F - 250°F	✓
	Cooling Water	Up to 50% Ethylene Glycol or Propylene Glycol Solution	300 psi	32°F - 250°F	✓
	Hot & Cold Potable Water		300 psi	32°F - 250°F	✓
	Hydronic Heating	Ethylene Glycol/Propylene Glycol	300 psi	32°F - 250°F	✓
	Low-Pressure Steam		Up to 15 psi	248°F	✓
	Rainwater/Gray Water		300 psi	32°F - 250°F	✓
FUEL, OIL & LUBRICANT	Ethanol	Pure Grain Alcohol	300 psi	32°F - 250°F	✓
GAS	Argon	Welding Use	300 psi	Ambient	✓
	Carbon Dioxide - CO ₂	Dry	300 psi	32°F - 250°F	✓
	Compressed Air	Less Than 25mg/m ³ Oil Content	300 psi	32°F - 250°F	✓
	Hydrogen - H ₂		125 psi	0°F - 250°F	✓
	Nitrogen - N ₂		300 psi	32°F - 250°F	✓
	Oxygen - O ₂ (Non-Med)	Keep Oil and Fat Free/Non-Liquid O ₂	140 psi	Up to 140°F	✓
	Vacuum		29.2 in Hg	Call	✓

*Contact Merit Brass for information regarding specific applications

SYSTEM DATA

CopperPress® Fitting Codes & Standards

- ASME B31.1 Power Piping, B31.3 Process Piping, B31.9 Building Services Piping
- IPC, IMC, IRC, UPC, UMC
- CPC & CMC (California Plumbing and Mechanical Codes)
- City of Los Angeles Plumbing and Mechanical Codes
- Massachusetts Regulation 248 CMR 10.00: Uniform State Plumbing Code
- Massachusetts State Building Code 780 CMR Ninth Edition: Chapter 28

CopperPress® Fitting Certifications

- ICC-ES LC 1002 Press Connection Fittings for Potable Water Tube and Radiant Heating Systems
- IAPMO/ANSI/CAN Z1117 Press Connections
- NSF/ANSI/CAN 61 Drinking Water System Components – Health Effects
- NSF/ANSI/CAN 372 Drinking Water System Components – Lead Content

CopperPress® Fitting Pressures & Temperatures

- **Temperature Range:** 0°F to 250°F
- **Operating Pressure:** 300 psi.



TOOLING REFERENCE GUIDE

CopperPress® Tools, Kits, Jaws and Rings							
Size	Milwaukee Part #	Tooling Name	Adapter	Ridgid Part #	Tooling Name	Adapter	Profile
0.5" - 4"	2773-20	M18 Force Logic Press Tool		67063	RP 350 Press Tool		
0.5" - 2"	2773-22	M18 Force Logic Press Tool w/Jaws (0.5" - 2")		67053	RP 350 Press Tool w/Jaws (0.5" - 2")		
0.5"	49-16-2650	0.5" M18 Jaw		76652	0.5" Press Jaw		CTS - V
0.75"	49-16-2651	0.75" M18 Jaw		76657	0.75" Press Jaw		CTS - V
1"	49-16-2652	1" M18 Jaw		76662	1" Press Jaw		CTS - V
1.25"	49-16-2653	1.25" M18 Jaw		76667	1.25" Press Jaw		CTS - V
1.5"	49-16-2654	1.5" M18 Jaw		76672	1.5" Press Jaw		CTS - V
2"	49-16-2655	2" M18 Jaw		76677	2" Press Jaw		CTS - V
2.5"	49-16-2656	2.5" M18 Ring	49-16-2659	20543	2.5" Press Ring	21878	CTS - Grab Ring
3"	49-16-2657	3" M18 Ring	49-16-2659	20548	3" Press Ring	21878	CTS - Grab Ring
4"	49-16-2658	4" M18 Ring	49-16-2659	20553	4" Press Ring	21878	CTS - Grab Ring
2.5" - 4"	49-16-2659	Ring Jaw 1		21878	V2 Press Ring Actuator		
2.5" - 4"	49-16-2690	M18 Press Ring Kit (2.5" - 4")		20483	2.5" - 4" Press Rings and V2 Actuator		

PRODUCT OFFERING

EPDM (Potable Water)			
	Description	Diameter Range CTS (Copper Tube Size)	
		Small Diameter	XL Diameter
	CopperPress® Coupling with Stop	1/2" - 2"	2-1/2" - 4"
CopperPress® Coupling without Stop	1/2" - 2"	2-1/2" - 4"	
CopperPress® Extended Coupling without Stop	1/2" - 2"		
CopperPress® Coupling Reducer	3/4" - 2"	2-1/2" - 4"	
CopperPress® Bushing Reducer	3/4" - 2"	2-1/2" - 4"	
CopperPress® 90° Elbow	1/2" - 2"	2-1/2" - 4"	
CopperPress® 90° Reducing Elbow	3/4" - 1"		
CopperPress® 90° Street Elbow	1/2" - 2"	2-1/2" - 4"	
CopperPress® 90° Drop Ear Elbow	3/8" - 3/4"		
CopperPress® 90° Male Elbow P x MPT	1/2" - 2"		
CopperPress® 90° Female Elbow P x FPT	1/2" - 2"		
CopperPress® 45° Elbow	1/2" - 2"	2-1/2" - 4"	
CopperPress® 45° Street Elbow	1/2" - 2"	2-1/2" - 4"	
CopperPress® Equal Tee	1/2" - 2"	2-1/2" - 4"	
CopperPress® Unequal Tee	3/4" - 2"	2-1/2" - 4"	
CopperPress® Reducing Tee	1/2" - 2"	2-1/2" - 4"	
CopperPress® Female Tee P x P x FPT	1/2" - 3/4"		
CopperPress® Female Reducing Tee P x P x FPT	3/4" - 2"	2-1/2" - 4"	
CopperPress® Cap	1/2" - 2"	2-1/2" - 4"	
CopperPress® Cross Over	1/2" - 3/4"		
CopperPress® Street Cross Over	1/2" - 3/4"		
CopperPress® Male Adapter	1/2" - 2"	2-1/2" - 4"	
CopperPress® Male Street Adapter	1/2" - 2"		
CopperPress® Female Adapter	1/2" - 2"	2-1/2" - 4"	
CopperPress® Female Street Adapter	1/2" - 2"		
CopperPress® Union	1/2" - 2"		
CopperPress® Male Union	1/2" - 2"		
CopperPress® Female Union	1/2" - 2"		
CopperPress® Dielectric Female Union	1/2" - 2"		
CopperPress® Pex Adapter	1/2" - 1"		
CopperPress® Flange Adapter	1" - 2"	2-1/2" - 4"	
CopperPress® Ball Valve	1/2" - 2"		

SEALING ELEMENTS

EPDM SEALING ELEMENT		
EPDM	Ethylene-propylene-diene monomer	
Color	Black	
Temperature	0°F to 250°F	
Common Applications	Potable Water	
	Hydronic Heating (W/ Glycol)	
	Chilled Water	
Manufacturing Process	Synthetically manufactured & peroxide-cured	
Benefits of Sealing Element	Excellent oxidation resistance	

SMALL DIAMETER COPPER END PRESS BALL VALVE - SIZES: 1/2" - 2"

CopperPress® Ball Valve Codes & Standards

- ASME B31.1 Power Piping, B31.3 Process Piping, B31.9 Building Services Piping
- ASME A112.4.14/CSA B125.14 Manually and Automatically Operated Valves for Use in Plumbing Systems
- IPC, IMC, IRC, UPC, UMC
- CPC & CMC (California Plumbing and Mechanical Codes)
- City of Los Angeles Plumbing and Mechanical Codes
- Massachusetts Regulation 248 CMR 10.00: Uniform State Plumbing Code
- Massachusetts State Building Code 780 CMR Ninth Edition: Chapter 28

CopperPress® Ball Valve Certifications

- ICC-ES LC 1002 Press Connection Fittings for Potable Water Tube and Radiant Heating Systems
- IAPMO/ANSI/CAN Z1157 Ball Valves
- NSF/ANSI/CAN 61 Drinking Water System Components – Health Effects
- NSF/ANSI/CAN 372 Drinking Water System Components – Lead Content

Design Features

Designed to be used with ASTM B88 Type K, L and M 1/2" - 2" copper tubing in the hard-drawn condition and soft copper tubing in sizes 1/2" - 1-1/4".

VIPR® (Visual Indicator Press Ring®)
facilitates immediate identification
of un-pressed connections

Suitable for installation in most plumbing
and heating systems including hydronic
heating, low pressure steam (15 psi max),
and potable water

Lead-Free Construction - Cast
C89836 Bronze Body with
Copper Retainers

**Maximum Working
Pressure:** 300 psi

Temperature Range:
0°F to 250°F

Leak Before Press in addition to the
VIPR®, the valve sealing element includes
a 4-path LBP system that guarantees a
visual indication if not pressed

Copper Ends - protect against dezincification
and stress corrosion cracking

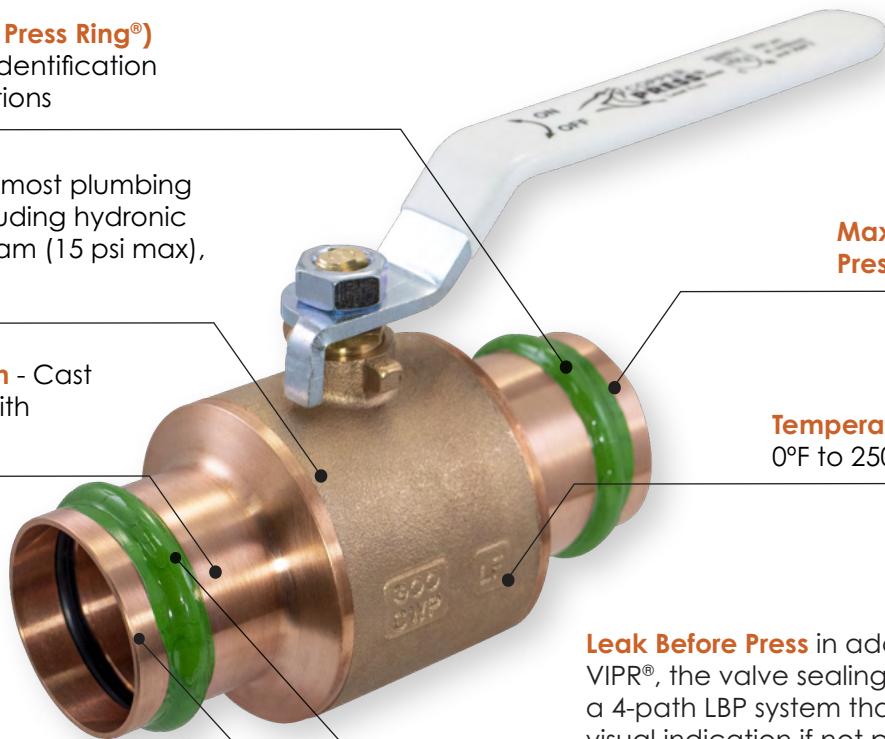

Small Diameter Copper End Press Ball Valve

Sizes: 1/2" - 2"

Item	Description	Material	QTY	Specification
1	Retainer	Copper	2	C12200
2	Seat	PTFE	2	
3	Body	Bronze	1	C89836
4	Ball (Sizes 1/2" - 1")	Chrome Plated Brass	1	C46500
4	Ball (Sizes 1-1/4" - 2")	Stainless Steel	1	304
5	Stem Packing	PTFE	1	
6	Packing Gland	Brass	1	HPb59-3P
7	Stem Nut	Zinc Plated Steel	1	Q235
8	Stem	Brass	1	C46500
9	Handle	Zinc Plated Steel	1	Q235
10	Sealing Element	EPDM	2	

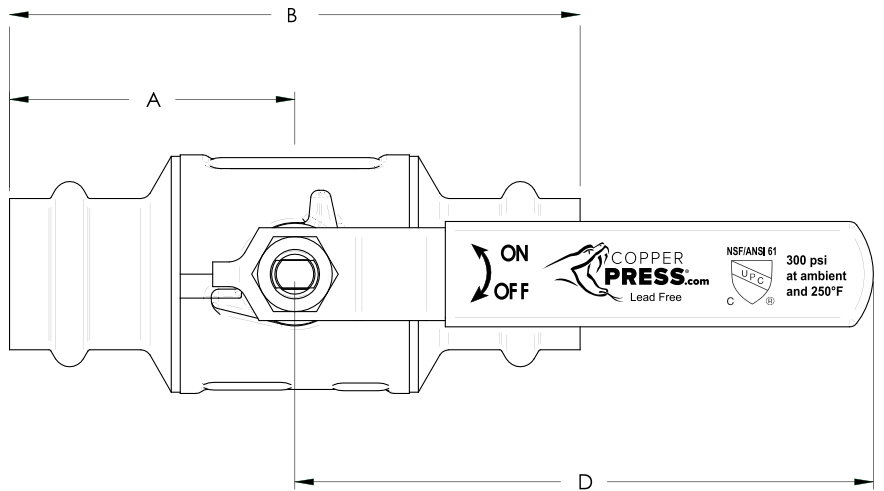
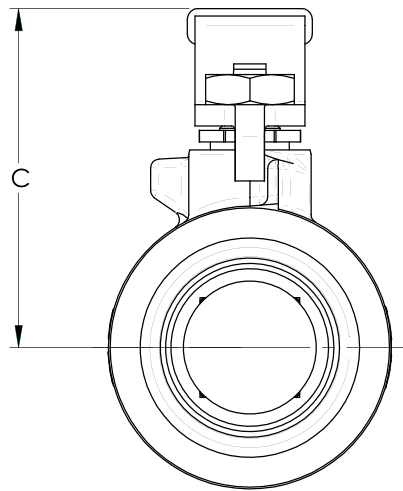
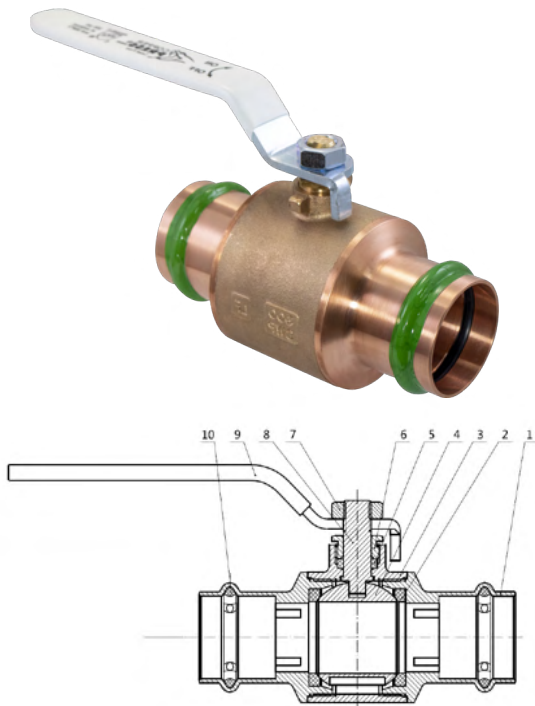

Part Number	Size (In)	A	B	C	D	Weight (lbs)
MB70000	1/2"	1.56	3.11	1.70	3.94	0.54
MB70010	3/4"	1.89	3.78	1.84	3.94	0.79
MB70020	1"	2.24	4.49	2.37	4.92	1.39
MB70030	1-1/4"	2.56	5.12	3.02	5.84	2.74
MB70040	1-1/2"	2.83	5.67	3.16	6.30	4.30
MB70050	2"	3.44	6.89	4.21	7.87	7.30

Find us in

MasterSpec®

Powered by Deltek Specpoint®



CarbonPress®
By Merit Brass Co.

Innovative Solutions

Driven to Provide Value to Your System



**MERIT
BRASS**
DIRECTING THE FLOW OF *Quality*

www.meritbrass.com
www.mbwebxpress.com

Streamlining Project Planning & Execution

Save **30-50%** in project planning, cost & execution



Supporting Distribution Growth Strategies Through Vertical Market Relationship Building



Training at Every Stage of the Process with Your Success in Mind



Saves Time, Money & Labor

No Soldering or Burn Permit Needed. Shorter Lay Lengths for Those Tighter Spaces

FEATURES & BENEFITS

EPDM & HNBR

Available in Sizes 1/2" – 2". The patented Visual Indicator Press Ring® (VIPR®) gives redundancy in identifying unpressed connections. The color-coded plastic sleeve can be easily removed when the connection is pressed, and also indicates the sealing element material preventing costly and potentially unsafe installation errors.



Box, Bag and Ring are color-coordinated for ease of identifying the sealing element

Most Comprehensive Package with over 400 SKUs

Grab Ring deforms and grips outside diameter of pipe

Engineered sealing elements are designed to leak before they are pressed, giving a visual indication of a connection that has not been pressed.



Corrosion resistant Zn-Ni plating ensures years of trouble-free service.

PRODUCT OFFERING

Description	Diameter Size Range for All Sealing Element Materials IPS (Iron Pipe Size)
	Small Diameter
CarbonPress® Coupling with Stop	1/2" - 2"
CarbonPress® Coupling No Stop	1/2" - 2"
CarbonPress® Extended Coupling No Stop	1/2" - 2"
CarbonPress® Bushing Reducer	3/4" - 2"
CarbonPress® Reducing Coupling	3/4" - 2"
CarbonPress® 90° Elbow	1/2" - 2"
CarbonPress® 90° Street Elbow	1/2" - 2"
CarbonPress® 45° Elbow	1/2" - 2"
CarbonPress® 45° Street Elbow	1/2" - 2"
CarbonPress® Equal Tee	1/2" - 2"
CarbonPress® Reducing Tee	1/2" - 2"
CarbonPress® Female Reducing Tee (P x FPT)	3/4" - 2"
CarbonPress® Cap	1/2" - 2"
CarbonPress® Male Adapter	1/2" - 2"
CarbonPress® Female Adapter	1/2" - 2"
CarbonPress® Union	1/2" - 2"
CarbonPress® Female Union	1/2" - 2"
CarbonPress® Flange Adapter	1/2" - 2"

APPROVED APPLICATIONS

TYPES OF SERVICE		SYSTEM OPERATING CONDITIONS			CARBONPRESS® SEALS	
		NOTES	PRESSURE	TEMPERATURE	EPDM (WATER)	HNBR (GAS)
FLUIDS/ WATER	Chilled Water	Low-Pressure System Steam	230 psi	Min. -40°F	✓	
	Hydronic Heating	Ethylene Glycol, Propylene Glycol	230 psi	300°F	✓	
	Low-Pressure System Steam		15 psi max.	300°F	✓	
GASES	Argon		230 psi	Max. 140°F	✓	✓
	Carbon Dioxide		230 psi	Max. 140°F	✓	✓
	Compressed Air	Oil Concentrate <25mg/m3	230 psi	Max. 140°F	✓	✓
		Oil Concentrate >25mg/m3	230 psi	Max. 140°F		✓
	Natural Gas, LP Gas -40°F to 180°F and Fuel Oil		125 psi max.	-40°F to 180°F		✓
	Nitrogen		230 psi	Max. 140°F	✓	✓
	Vacuum		29.2 in Hg max.	Max. 140°F		
OIL & LUBRICANTS	Diesel Fuel	Compliant with NFPA 30 & 30A	125 psi			✓
	Engine Oil		150 psi	Ambient		✓
	Heating Fuel Oil		125 psi	-40°F to 180°F		✓
	Hydraulic Fluid	Mineral Based	230 psi	Ambient		✓
	Transmission Fluid		230 psi	Ambient		✓

Contact Merit Brass for additional information regarding applications not listed above.

SEALING ELEMENTS

EPDM SEALING ELEMENT	
EPDM	Ethylene-propylene-diene monomer
Color	Black
Temperature	-40°F to 300°F (-40°C to 148°C)
Common Applications	Hydronic Heating
	Chilled Water
	Oil Free Air
Manufacturing Process	Synthetically manufactured & peroxide-cured
Benefits of Sealing Element	Excellent oxidation resistance



HNBR SEALING ELEMENT	
HNBR	Hydrogenated Nitrile Butadiene Rubber
Color	Yellow
Temperature	-40°F to 200°F (-40°C to 93°C)
Common Applications	Fuel Gas Applications
	Petroleum-based products and lubricants
	Salt solutions
Manufacturing Process	Synthetically manufactured and peroxide-cured
Benefits of Sealing Element	Excellent resilience and tear resistance



SYSTEM DATA

CarbonPress® Codes and Standards

- ASME B31.1 Power Piping
- ASME B31.3 Process Piping
- ASME B31.9 Building Service Piping
- CSA B149.1 Natural Gas and Propane Installation Code
- IAPMO Uniform Mechanical Code (UMC)
- IAPMO Uniform Plumbing Code (UPC)

CarbonPress® Certifications

- IAPMO Z 1117 (EPDM)
- IAPMO/ANSI LC 4/CSA 6.32 (HNBR)

CarbonPress® Temperature & Pressure

- **Temperature Range:** EPDM -40°F to 300°F (-40°C to 148°C)
Working pressure range from full vacuum to 250 psi (17.2 bar) for water
- **Temperature Range:** HNBR -40°F to 200°F (-40°C to 93°C)
Working pressure range 125 psi (8.6 bar) for gas
- **Surface Protection:** Corrosion Resistant Zn-Ni Plating



TOOLING REFERENCE GUIDE

CarbonPress® Tools, Kits, Jaws and Rings

Size	Milwaukee Part #	Tooling Name	Adapter	Ridgid Part #	Tooling Name	Adapter	Profile
0.5" - 2"	2773-20	M18 Force Logic Press Tool		67063	RP 350 Press Tool		
0.5" - 1"	49-16-2696	M18 Black Iron Press Kit (0.5" - 1")		48558	Press Jaw Kit (0.5" - 1")		
0.5" - 2"	49-16-2697	M18 Black Iron Press Kit (0.5" - 2")		48553	Press Jaw Kit (0.5" - 2")		
2.5" - 4"	2773-20L	M18 Force Logic Long Throw Press Tool		60658	Press Booster		
0.5"	49-16-2650B	0.5" M18 Black Iron Press Jaw		37958	0.5" Press Jaw		IPS - Grab Ring
0.75"	49-16-2651B	0.75" M18 Black Iron Press Jaw		37963	0.75" Press Jaw		IPS - Grab Ring
1"	49-16-2652B	1" M18 Black Iron Press Jaw		37968	1" Press Jaw		IPS - Grab Ring
1.25"	49-16-2653B	1.25" M18 Black Iron Press Ring	49-16-2659	37973	1.25" Press Ring	21878	IPS - Grab Ring
1.5"	49-16-2654B	1.5" M18 Black Iron Press Ring	49-16-2659	37978	1.5" Press Ring	21878	IPS - Grab Ring
2"	49-16-2655B	2" M18 Black Iron Press Ring	49-16-2659	37983	2" Press Ring	21878	IPS - Grab Ring
2.5"	49-16-2656B	2.5" M18 Black Iron Press Ring	49-16-2659	60643	2.5" Press Ring	Press Booster	IPS - Grab Ring
3"	49-16-2657B	3" M18 Black Iron Press Ring	49-16-2659	60648	3" Press Ring	Press Booster	IPS - Grab Ring
4"	49-16-2658B	4" M18 Black Iron Press Ring	49-16-2659	64653	4" Press Ring	Press Booster	IPS - Grab Ring
1.25" - 2"	49-16-2659	Ring Jaw 1		21878	V2 Press Ring Actuator		
2.5" - 4"	49-16-2659S	Ring Jaw 2					
2.5" - 4"	49-16-2698	M18 Black Iron Press Kit XL (2.5" - 4")		60638	Press Booster with Press Rings (2.5" - 4")		

Note: CarbonPress®, by Merit Brass Co. products can be used with Milwaukee, REMS, Ridgid, and Rothenberger tools with the associated Jaws for Carbon Steel/Black Iron Pipe. Please contact Merit Brass Co. for additional information.

Find us in

MasterSpec®

Powered by Deltek Specpoint®



StainlessPress®

Isotubi-USA, By Merit Brass Co.

Innovative Solutions

Driven to Provide Value to Your System



**MERIT
BRASS**
DIRECTING THE FLOW OF *Quality*

www.meritbrass.com
www.mbwebxpress.com

Streamlining Project Planning & Execution

Save **30-50%** in project planning, cost & execution



Supporting Distribution Growth Strategies Through Vertical Market Relationship Building



Training at Every Stage of the Process with Your Success in Mind



Saves Time, Money & Labor

No Soldering or Burn Permit Needed. Shorter Lay Lengths for Those Tighter Spaces

FEATURES & BENEFITS

EPDM & HNBR

15-Year Limited Warranty on Fittings & 5-Year Limited Warranty on StainlessPress® Valves. VIPR® facilitates immediate identification of unpressed connection as well as application.



IPS (Iron Pipe Size)

4 Path Leak Before Press (LBP) System

Buy American Act

316 Stainless Steel

Origin: Barcelona, Spain

Mates with S5 & S10, 304 & 316 Stainless Steel Pipe



Box, bag and ring are Color-Coordinated to the Sealing Element

PRODUCT OFFERING



Description	Size Range
316 StainlessPress® Coupling with Stop	1/2" - 2"
316 StainlessPress® Coupling without Stop	1/2" - 2"
316 StainlessPress® 90° Elbow	1/2" - 2"
316 StainlessPress® 90° Street Elbow	1/2" - 2"
316 StainlessPress® 45° Elbow	1/2" - 2"
316 StainlessPress® 45° Street Elbow	1/2" - 2"
316 StainlessPress® Tee P x P x FPT	1/2" - 2"
316 StainlessPress® Tee P x P x P	1/2" - 2"
316 StainlessPress® Reducing Tee P x P x FPT	3/4" - 2"
316 StainlessPress® Reducing Tee P x P x P	3/4" - 2"
316 StainlessPress® Bushing Reducer	3/4" - 2"
316 StainlessPress® Female Adapter	1/2" - 2"
316 StainlessPress® Male Adapter	1/2" - 2"
316 StainlessPress® Flange Adapter	1/2" - 2"
316 StainlessPress® Cap	1/2" - 2"
316 StainlessPress® Union	1/2" - 2"
316 StainlessPress® Ball Valve	1/2" - 2"
316 StainlessPress® Transition Adapter	3/4" - 2"
316 StainlessPress® Van Stone Flange Adapter	1/2" - 2"
316 StainlessPress® Weld Adapter	1/2" - 2"

Note: Size range is for all sealing element materials (HNBR, EPDM and FKM)

SYSTEM DATA

StainlessPress® Fitting Codes & Standards

- ASME B31.1 Power Piping, B31.3 Process Piping, B31.9 Building Services Piping
- IPC, IMC, UPC, UMC
- CPC & CMC (California Plumbing and Mechanical Codes)
- City of Los Angeles Plumbing and Mechanical Codes
- Massachusetts Regulation 248 CMR 10.00: Uniform State Plumbing Code
- Massachusetts State Building Code 780 CMR Ninth Edition: Chapter 28
- National Standard Plumbing Code (NSPC)
- National Plumbing Code of Canada (NPCC)

StainlessPress® Fitting Certifications

- ICC-ES LC 1002 Press Connection Fittings for Potable Water Tube and Radiant Heating Systems
- IAPMO/ANSI/CAN Z1117 Press Connections
- NSF/ANSI/CAN 61 Drinking Water System Components – Health Effects
- NSF/ANSI/CAN 372 Drinking Water System Components – Lead Content
- FM 1920 Pipe Coupling and Fittings for Above Ground Fire Protection Systems
- American Bureau of Shipping Product Design Assessment (PDA) Certificate 1-5-PR1438892-PDA, Piping System and Couplings

StainlessPress® Fitting Temperature & Pressure

- **Operating Pressure:** from full vacuum to 300 PSI on Schedule 5 or 10 Stainless Steel Pipe
- **Temperature Range EPDM:** -4°F to 230°F (-20°C to 110°C)
- **Temperature Range HNBR:** -31°F to 248°F (-35°C to 120°C)

NOTE: Code, standard and certification compliance is sealing element dependent. Only products with EPDM seals are suitable for potable water applications. Contact Merit Brass Customer Service for additional information.

Limited Warranty



We stand behind the quality of our products and offer a **15-year limited warranty*** on our **StainlessPress®** fitting offering. We guarantee that our fittings will be free from defects in materials and workmanship for 15 years from the date of purchase. If any of our fittings fail due to defects during this time, we will replace or repair the product at no cost to the customer.

*This warranty does not cover damage caused by improper installation, misuse, or normal wear and tear.

CHEMICAL COMPATIBILITY CHART

	CHEMICAL	CHEMICAL FORMULAS	316 SS	SEALING ELEMENT			VALVE SEAT
				EPDM	HNBR	FKM	PTFE
ACIDS	Acetic Acid 5%	$C_2H_4O_2$	A	A	B	A	A
	Acetic Acid 10%	$C_2H_4O_2$	A	A	C	B	A
	Acetic Acid Glacial	$C_2H_4O_2$	A	A	B	D	A
	Boric Acid 20%	H_3BO_3	A	A	A	A	A
	Nitric Acid 20°C	HNO_3	A	D	D	B	A
BASES	Ammonium Hydroxide Concentrated	NH_4OH	A	A	D	B	A
	Potassium Hydroxide 50% 20°C	KOH	A	A	B	D	A
GASES	Acetylene	C_2H_2	A	A	A	A	A
	Air		A	A	A	A	A
	Argon	Ar	A	A	A	A	A
	Butane	C_4H_{10}	A	D	A	A	A
	Carbon Dioxide	CO_2	A	A	A	A	A
	Carbon Monoxide	CO	A	A	A	A	A
	Ethyl Chloride (no moisture)	C_2H_5Cl	A	B	A	A	A
	Helium	He	A	A	A	A	A
	Hydrogen	H_2	A	A	A	A	A
	Hydrogen Sulfide	H_2S	A	A	A	D	A
	Methane	CH_4	A	D	A	A	A
	Neon	Ne	A	A	A	A	A
	Nitrogen	N	A	A	A	A	A
	Propane	C_3H_8	A	D	A	A	A
	Xenon	Xe	A	A	A	A	A
ALCOHOLS	Amyl Alcohol	$C_5H_{11}OH$	A	A	B	B	A
	Butyl Alcohol (Butanol)	$C_4H_{10}O$	A	B	A	A	A
	Ethyl Alcohol < 80%	C_2H_6O	A	A	A	B	A
	Ethyl Alcohol > 80%	C_2H_6O	A	A	A	B	A
	Glycerine (Glycerol)	$C_3H_5(OH)_3$	A	A	A	A	A
	Isopropyl Alcohol	C_3H_8O	A	A	B	A	A
	Methanol	CH_3OH	A	A	A	D	A

A = Recommended B = Minor Effect C = Moderate Effect D = Unsatisfactory

Recommendations shown above are general in nature. Product service life for a given application is dependent on actual media mixture, pressure, temperature and operational (cycling) parameters. Contact sales@meritbrass.com if you have questions or wish to inquire about compatibility with chemicals not shown in the chart.

SEALING ELEMENTS

Sealing element is resistant to hot water, ageing and additives commonly used in drinking water. EPDM and Nitrile are certified to all requirements of NSF/ANSI 61, Annex G and NSF/ANSI 372.

EPDM SEALING ELEMENT	
EPDM	Ethylene-propylene-diene monomer
Color	Black
Temperature	Fittings & Valves: -4°F to 230°F (-20°C to 110°C)
Common Applications	Recommended for hot water, dilute acids, alkalis, oil free air and many chemical services. Excellent oxidation resistance. NOT FOR USE WITH HYDROCARBONS
Manufacturing Process	Synthetically manufactured & peroxide-cured
Benefits of Sealing Element	Excellent oxidation resistance

HNBR SEALING ELEMENT	
HNBR	Hydrogenated Nitrile Butadiene Rubber
Color	Yellow
Temperature	Fittings: -31°F to 248°F (-35°C to 120°C) Valves: -13°F to 248°F (-25°C to 120°C)
Common Applications	Recommended for petroleum products, vegetable oils, mineral oils and air with oils. NOT FOR USE IN HOT WATER OR HOT AIR.
Manufacturing Process	Synthetically manufactured & peroxide-cured
Benefits of Sealing Element	Excellent resilience and tear resistance

TOOLING REFERENCE GUIDE

StainlessPress® Tools, Kits, Jaws and Rings				
Size	Milwaukee Part #	Tooling Name	Adapter	Ridgid Part #
0.5" - 1.25"	2773-20	M18 Force Logic Press Tool		
1.5" - 2"	2773-20L	M18 Force Logic Long Throw Press Tool		
0.5"	49-16-2650S	0.5" M18 IPS-IA Jaw		IPS - M
0.75"	49-16-2651S	0.75" M18 IPS-IA Jaw		IPS - M
1"	49-16-2652S	1" M18 IPS-IA Jaw		IPS - M
1.25"	49-16-2653S	1.25" M18 IPS-IA Ring	49-16-2659	IPS - M
1.5"	49-16-2654S	1.5" M18 IPS-IA Ring	49-16-2659S	IPS - M
2"	49-16-2655S	2" M18 IPS-IA Ring	49-16-2659S	IPS - M
1.25"	49-16-2659	Ring Jaw 1		
1.5" - 2"	49-16-2659S	Ring Jaw 2		
1.25" - 2"	49-16-2691S	M18 IPS-IA Press Ring Kit (1.25" - 2")		



THREE PIECE BALL VALVE | SIZES: 1/2" - 2"

StainlessPress® Ball Valve Codes & Standards

In compliance with the Buy American Act

- ASME B31.1 Power Piping, B31.3 Process Piping, B31.9 Building Services Piping
- IPC, IMC, UPC, UMC
- CPC & CMC (California Plumbing and Mechanical Codes)
- City of Los Angeles Plumbing and Mechanical Codes
- Massachusetts Regulation 248 CMR 10.00: Uniform State Plumbing Code
- Massachusetts State Building Code 780 CMR Ninth Edition: Chapter 28
- National Standard Plumbing Code (NSPC)
- National Plumbing Code of Canada (NPCC)

StainlessPress® Valve Certifications

- ICC-ES LC 1002 Press Connection Fittings for Potable Water Tube and Radiant Heating Systems
- IAPMO/ANSI/CAN Z1157 Ball Valves
- NSF/ANSI/CAN 61 Drinking Water System Components – Health Effects
- NSF/ANSI/CAN 372 Drinking Water System Components – Lead Content

Design Features

VIPR® (Visual Indicator Press Ring®)
facilitates immediate identification of un-pressed connections

Temperature Range (HNBR)
-13°F to 248°F (-25°C to 120°C)

HNBR

Leak Before Press - in addition to the VIPR®, valve incorporates four path LBP technology, guaranteeing a visual indication if not pressed

Latch-Lock Handle
facilitates locking in the open and closed positions

Full Port Quarter-Turn Valve

Maximum Working Pressure - 300 psi

IPS (Iron Pipe Size) used with schedule 5 or 10 stainless steel pipe

EPDM

Temperature Range (EPDM)
-4°F to 230°F (-20°C to 110°C)



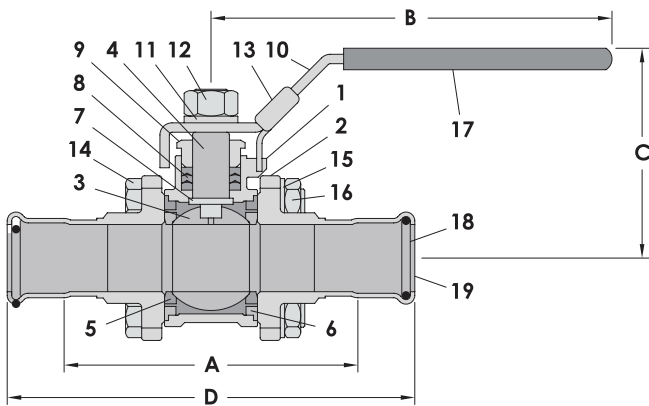

StainlessPress® Three Piece Ball Valve			Sizes: 1/2" - 2"
NO.	Part Name	QTY	Material
1	Body	1	ASTM A351-CF8M
2	Cap	1	ASTM A351-CF8M
3	Ball	1	ASTM A351-CF8M
4	Stem	1	ASTM A276-316
5	Ball Seat	1	RPTFE
6	Body Seat	1	Graphite-Filled PTFE
7	Thrust Washer	1	Graphite-Filled PTFE
8	Stem Packing	1	PTFE
9	Gland Nut	1	AISI 304
10	Handle	1	AISI 304
11	Spring Washer	1	AISI 304
12	Nut	1	AISI 304
13	Latch Lock	1	AISI 304
14	Bolt	4	AISI 304
15	Spring Washer	4	AISI 304
16	Nut	4	AISI 304
17	Handle Sleeve	1	PVC
18	Sealing Element	2	EPDM, Nitrile, Fluoroelastomer*
19	StainlessPress® Ends	2	316L

*For more information on Fluoroelastomer Sealing Elements, please contact Merit.

Part Number		Inches	Dimensions (in)				Weight (lbs)
EPDM	HNBR	Nominal	A	B	C	D	
MBF311/26GE	MBF311/26GEH	1/2	2.82	4.26	2.44	4.49	1.24
MBF313/46GE	MBF313/46GEH	3/4	3.50	5.31	2.68	5.39	1.73
MBF3116GE	MBF3116GEH	1	3.86	5.30	2.75	5.90	2.46
MBF3111/46GE	MBF3111/46GEH	1-1/4	4.17	6.30	3.35	6.53	5.90
MBF3111/26GE	MBF3111/26GEH	1-1/2	4.72	7.87	3.54	7.13	5.93
MBF3126GE	MBF3126GEH	2	5.35	8.27	3.94	8.89	8.48

*For more information on Fluoroelastomer Sealing Elements, please contact Merit.



STAINLESS STEEL PIPE

Features

- Available in 1/2" - 12" & 16"
- Welded and Seamless
- Welded pipe available in bundles and sub-bundles
- Schedules 10, 40 and 80
- Schedule 10 Mates with StainlessPress® Fittings
- Meets ASTM A-312/ASME SA-312 Specification
- Meets NSF/ANSI 372 as a Lead-Free Product

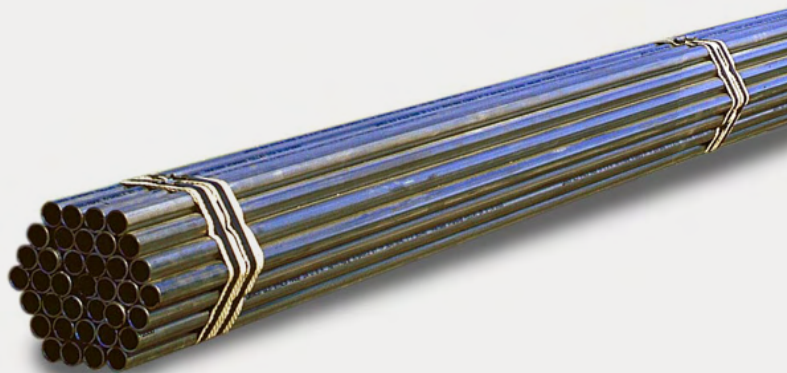

Used in Water Treatment, Wastewater Treatment, Oil, Gas, Chemical, Pharmaceutical, Medical, Commercial Plumbing, Residential Plumbing, Automotive, Transportation, Architecture, Construction, Power Generation, Food, Beverage, Pulp, Paper, OEM, and Petrochemical Applications

Standard Labeling

For welded pipe, all bundles are marked with a unique QR Code, which contains:



- Sub-Bundle Quantity Detail
- Merit Brass Co.'s Part Number
- ASTM A312/A312 Specification
- Alloy (304/L or 316/L)
- Diameter
- Merit Brass Purchase Order Number
- Bundle Quantity Detail
- Heat Number
- Date of Packaging

Merit offers regular flatbed services on our **WOW (Warehouse on Wheels)** Runs to safely transport your pipe. Available at all of our convenient locations





LOCATIONS

SPARKS DISTRIBUTION CENTER

200 Vista Boulevard Suite #106
Sparks, NV 89434

LONG BEACH PIPE DEPOT

2396 E. Artesia Blvd
Long Beach, CA 90805

DALLAS DISTRIBUTION CENTER

10614 King William Drive
Dallas, TX 75220

CLEVELAND HEADQUARTERS

One Merit Drive/PO Box 43127
Cleveland, OH 44143

BIRMINGHAM DISTRIBUTION CENTER

220 Oxmoor Court
Birmingham, AL 35209

HOUSTON DISTRIBUTION CENTER

4680 S. Sam Houston Pkwy W, Suite 120
Houston, TX 77053

CONTACT US



800.726.9800

contactus@meritbrass.com

LEARN MORE



Revised May 2023